













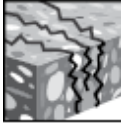
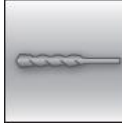

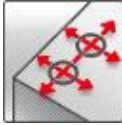
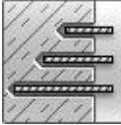
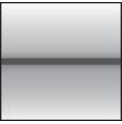
## Hilti HIT-RE 500 V3 mortar with HIT-V rod

Injection mortar system		Benefits
	Hilti HIT-RE 500 V3 330 ml, 500 ml and 1400 ml foil pack	<ul style="list-style-type: none"> <li>- <b>SafeSet</b> technology: Simplified method of borehole preparation leaving some of the cleaning steps out: Hilti hollow drill bit for hammer drilling and Roughening tool for diamond cored applications</li> <li>- suitable for cracked/non-cracked concrete C 20/25 to C 50/60</li> <li>- high loading capacity</li> <li>- suitable for dry and water saturated concrete</li> <li>- under water application</li> <li>- high corrosion resistance</li> <li>- long working time at elevated temperatures</li> <li>- cures down to -5°C</li> <li>- odourless epoxy</li> </ul>
	Static mixer	
	HIT-V rod	

<b>Base material</b>  Concrete (non-cracked)  Concrete (cracked)	<b>Installation conditions</b>  Hammer drilled holes  Diamond drilled holes  Hilti SafeSet technology  Small edge distance and spacing  Variable embedment depth
<b>Load conditions</b>  Static/quasi-static  Seismic, ETA-C1, C2  Fire resistance	<b>Other information</b>  European Technical Assessment  CE conformity  PROFIS Anchor design Software  Corrosion resistance A4 316  High corrosion resistance HCR highMo

### Approvals / certificates

Description	Authority / Laboratory	No. / date of issue
European Technical Assessment	CSTB	ETA-16/0143 / 2016-11-30
Fire test report	MFPA Leipzig	GS 3.2/15-361-4 / 2016-08-04

a) All data given in this section according to ETA-16/0143, issue 2016-11-30.

### Static and quasi-static resistance (for a single anchor)

**All data in this section applies to:**

- Correct setting (See setting instruction)
- No edge distance and spacing influence
- Steel failure
- Anchor HIT-V with strength class 5.8 and 8.8, anchor AM 8.8
- Base material thickness, as specified in the table
- One typical embedment depth as specified in the table
- Concrete C 20/25,  $f_{ck,cube} = 25 \text{ N/mm}^2$
- Temperature range I  
(min. base material temperature  $-40^\circ\text{C}$ , max. long/short term base material temperature:  $+24^\circ\text{C}/40^\circ\text{C}$ )
- Installation temperature range  $-5^\circ\text{C}$  to  $+40^\circ\text{C}$

**Embedment depth<sup>a)</sup> and base material thickness**

Anchor size	ETA-16/0143, issue 2016-11-30								Additional Hilti technical data		
	M8	M10	M12	M16	M20	M24	M27	M30	M33	M36	M39
Eff. Anchorage depth [mm]	80	90	110	125	170	210	240	270	300	330	360
Base material thickness [mm]	110	120	140	161	214	266	300	340	374	410	444

a) The allowed range of embedment depth is shown in the setting

**For hammer drilled holes, hollow drill bit<sup>1)</sup> and diamond cored with roughening tool<sup>2)</sup>:**

**Mean ultimate resistance**

Anchor size	ETA-16/0143, issue 2016-11-30								Additional Hilti technical data		
	M8	M10	M12	M16	M20	M24	M27	M30	M33	M36	M39
<b>Non cracked concrete</b>											
Tensile $N_{Ru,m}$ HIT-V 5.8 [kN]	18,9	30,5	44,1	83,0	129,2	185,9	241,5	295,1	348,4	401,9	457,9
Shear $V_{Ru,m}$ HIT-V 5.8 [kN]	9,5	15,8	22,1	41,0	64,1	92,4	120,8	147,0	182,7	214,2	256,2
<b>Cracked concrete</b>											
Tensile $N_{Ru,m}$ HIT-V 5.8 [kN]	17,4	28,2	44,0	66,7	105,9	145,4	177,7	212,0	-	-	-
Shear $V_{Ru,m}$ HIT-V 5.8 [kN]	9,5	15,8	22,1	41,0	64,1	92,4	120,8	147,0	-	-	-

1) Hilti hollow drill bit available for element size M12-M30.

2) Roughening tools are available for element size M16-M30.

**Characteristic resistance**

Anchor size		ETA-16/0143, issue 2016-11-30								Additional Hilti technical data		
		M8	M10	M12	M16	M20	M24	M27	M30	M33	M36	M39
<b>Non-cracked concrete</b>												
Tensile $N_{Rk}$	HIT-V 5.8	18,0	29,0	42,0	70,6	111,9	153,7	187,8	224,0	262,4	302,7	344,9
	HIT-V 8.8, AM 8.8	29,0	43,1	58,3	70,6	111,9	153,7	187,8	224,0	262,4	302,7	344,9
Shear $V_{Rk}$	HIT-V 5.8	9,0	15,0	21,0	39,0	61,0	88,0	115,0	140,0	174,0	204,0	244,0
	HIT-V 8.8, AM 8.8	15,0	23,0	34,0	63,0	98,0	141,0	184,0	224,0	278,0	327,0	390,0
<b>Cracked concrete</b>												
Tensile $N_{Rk}$	HIT-V 5.8	13,1	21,2	33,2	50,3	79,8	109,6	133,9	159,7	-	-	-
	HIT-V 8.8, AM 8.8	13,1	21,2	33,2	50,3	79,8	109,6	133,9	159,7	-	-	-
Shear $V_{Rk}$	HIT-V 5.8	9,0	15,0	21,0	39,0	61,0	88,0	115,0	140,0	-	-	-
	HIT-V 8.8, AM 8.8	15,0	23,0	34,0	63,0	98,0	141,0	184,0	224,0	-	-	-

- 1) Hilti hollow drill bit available for element size M12-M30.  
2) Roughening tools are available for element size M16-M30.

**Design resistance**

Anchor size		ETA-16/0143, issue 2016-11-30								Additional Hilti technical data		
		M8	M10	M12	M16	M20	M24	M27	M30	M33	M36	M39
<b>Non-cracked concrete</b>												
Tensile $N_{Rd}$	HIT-V 5.8	12,0	19,3	28,0	47,1	74,6	102,5	125,2	149,4	145,8	168,2	191,6
	HIT-V 8.8, AM 8.8	19,3	28,7	38,8	47,1	74,6	102,5	125,2	149,4	145,8	168,2	191,6
Shear $V_{Rd}$	HIT-V 5.8	7,2	12,0	16,8	31,2	48,8	70,4	92,0	112,0	139,2	163,2	195,2
	HIT-V 8.8, AM 8.8	12,0	18,4	27,2	50,4	78,4	112,8	147,2	179,2	222,4	261,6	312,0
<b>Cracked concrete</b>												
Tensile $N_{Rd}$	HIT-V 5.8	8,7	14,1	22,1	33,5	53,2	73,0	89,2	106,5	-	-	-
	HIT-V 8.8, AM 8.8	8,7	14,1	22,1	33,5	53,2	73,0	89,2	106,5	-	-	-
Shear $V_{Rd}$	HIT-V 5.8	7,2	12,0	16,8	31,2	48,8	70,4	92,0	112,0	-	-	-
	HIT-V 8.8, AM 8.8	12,0	18,4	27,2	50,4	78,4	112,8	147,2	179,2	-	-	-

- 1) Hilti hollow drill bit available for element size M12-M30.  
2) Roughening tools are available for element size M16-M30.

**Recommended loads <sup>a)</sup>**

Anchor size		ETA-16/0143, issue 2016-11-30								Additional Hilti technical data		
		M8	M10	M12	M16	M20	M24	M27	M30	M33	M36	M39
<b>Non cracked concrete</b>												
Tensile $N_{Rec}$	HIT-V 5.8	8,6	13,8	20,0	33,6	53,3	73,2	89,4	106,7	104,1	120,1	136,9
Shear $V_{Rec}$	HIT-V 5.8	5,1	8,6	12,0	22,3	34,9	50,3	65,7	80,0	99,4	116,6	139,4
<b>Cracked concrete</b>												
Tensile $N_{Rec}$	HIT-V 5.8	6,2	10,1	15,8	23,9	38,0	52,2	63,7	76,1	-	-	-
Shear $V_{Rec}$	HIT-V 5.8	5,1	8,6	12,0	22,3	34,9	50,3	65,7	80,0	-	-	-

- a) With overall partial safety factor for action  $\gamma=1,4$ . The partial safety factors for action depend on the type of loading and shall be taken from national regulations.

**For diamond drilling:**
**Mean ultimate resistance**

Anchor size		M8	M10	M12	M16	M20	M24	M27	M30
<b>Non cracked concrete</b>									
Tensile $N_{Ru,m}$	HIT-V 5.8	18,9	30,5	44,1	83,0	129,2	185,9	241,5	295,1
Shear $V_{Ru,m}$	HIT-V 5.8	9,5	15,8	22,1	41,0	64,1	92,4	120,8	147,0

**Characteristic resistance**

Anchor size		M8	M10	M12	M16	M20	M24	M27	M30
<b>Non cracked concrete</b>									
Tensile $N_{Rk}$	HIT-V 5.8	18,0	29,0	42,0	70,6	111,9	153,7	187,8	224,0
	HIT-V 8.8, AM 8.8	24,1	33,9	49,8	70,6	111,9	153,7	187,8	224,0
Shear $V_{Rk}$	HIT-V 5.8	9,0	15,0	21,0	39,0	61,0	88,0	115,0	140,0
	HIT-V 8.8, AM 8.8	15,0	23,0	34,0	63,0	98,0	141,0	184,0	224,0

**Design resistance**

Anchor size		M8	M10	M12	M16	M20	M24	M27	M30
<b>Non cracked concrete</b>									
Tensile $N_{Rd}$	HIT-V 5.8	12,0	18,8	27,6	33,6	53,3	73,2	89,4	106,7
	HIT-V 8.8, AM 8.8	13,4	18,8	27,6	33,6	53,3	73,2	89,4	106,7
Shear $V_{Rd}$	HIT-V 5.8	7,2	12,0	16,8	31,2	48,8	70,4	92,0	112,0
	HIT-V 8.8, AM 8.8	12,0	18,4	27,2	50,4	78,4	112,8	147,2	179,2

**Recommended loads<sup>a)</sup>**

Anchor size		M8	M10	M12	M16	M20	M24	M27	M30
<b>Non cracked concrete</b>									
Tensile $N_{Rec}$	HIT-V 5.8	8,6	13,5	19,7	24,0	38,1	52,3	63,9	76,2
Shear $V_{Rec}$	HIT-V 5.8	5,1	8,6	12,0	22,3	34,9	50,3	65,7	80,0

a) With overall partial safety factor for action  $\gamma=1,4$ . The partial safety factors for action depend on the type of loading and shall be taken from national regulations.

## Seismic resistance

### All data in this section applies to:

- Correct setting (See setting instruction)
- No edge distance and spacing influence
- Steel failure
- Anchor HIT-V strength class 8.8, anchor AM 8.8
- Base material thickness, as specified in the table
- One typical embedment depth as specified in the table
- Concrete C 20/25,  $f_{ck,cube} = 25 \text{ N/mm}^2$
- Temperature range I  
(min. base material temperature  $-40^\circ\text{C}$ , max. long/short term base material temperature:  $+24^\circ\text{C}/40^\circ\text{C}$ )
- Installation temperature range  $-5^\circ\text{C}$  to  $+40^\circ\text{C}$
- $\alpha_{gap}=1,0$  (using Hilti seismic filling set)

### Embedment depth and base material thickness for seismic C1 and C2

Anchor size	M8	M10	M12	M16	M20	M24	M27	M30
Eff. Anchorage depth [mm]	80	90	110	125	170	210	240	270
Base material thickness [mm]	110	120	140	165	220	270	300	340

### For hammer drilled holes, hollow drill bit and diamond cored with roughening tool:

#### Characteristic resistance in case of seismic performance category C1

Anchor size	M8	M10	M12	M16	M20	M24	M27	M30
Tensile $N_{Rk}$ HIT-V 8.8, AM 8.8 [kN]	12,1	19,8	32,8	42,8	67,8	93,1	113,8	135,8
Shear $V_{Rk}$ HIT-V 8.8, AM 8.8 [kN]	15,0	23,0	34,0	63,0	98,0	141,0	184,0	224,0

#### Design resistance in case of seismic performance category C1

Anchor size	M8	M10	M12	M16	M20	M24	M27	M30
Tensile $N_{Rd}$ HIT-V 8.8, AM 8.8 [kN]	8,0	13,2	21,8	28,5	45,2	62,1	75,9	90,5
Shear $V_{Rd}$ HIT-V 8.8, AM 8.8 [kN]	12,0	18,4	27,2	50,4	78,4	112,8	147,2	179,2

### For hammer drilled holes and hammer drilled holes with Hilti hollow drill bit:

#### Characteristic resistance in case of seismic performance category C2 using Hilti seismic filling set

Anchor size	M8	M10	M12	M16	M20	M24	M27	M30
Tensile $N_{Rk}$ HIT-V 8.8, AM 8.8 [kN]	-	-	-	34,6	57,7	80,8	-	-
Shear $V_{Rk}$ HIT-V 8.8, AM 8.8 [kN]	-	-	-	46,0	77,0	103,0	-	-

#### Design resistance in case of seismic performance category C2 using Hilti seismic filling set

Anchor size	M8	M10	M12	M16	M20	M24	M27	M30
Tensile $N_{Rd}$ HIT-V 8.8, AM 8.8 [kN]	-	-	-	23,0	38,5	53,8	-	-
Shear $V_{Rd}$ HIT-V 8.8, AM 8.8 [kN]	-	-	-	36,8	61,6	82,4	-	-

## Materials

### Mechanical properties

Anchor size		ETA-16/0143, issue 2016-11-30								Additional Hilti Technical data		
		M8	M10	M12	M16	M20	M24	M27	M30	M33	M36	M39
Nominal tensile strength $f_{uk}$	HIT-V 5.8	500	500	500	500	500	500	500	500	500	500	500
	HIT-V 8.8	800	800	800	800	800	800	800	800	800	800	800
	AM 8.8 [N/mm <sup>2</sup> ]	800	800	800	800	800	800	800	800	800	800	800
	HIT-V-R	700	700	700	700	700	700	500	500	500	500	500
	HIT-V-HCR	800	800	800	800	800	700	700	700	500	500	500
Yield strength $f_{yk}$	HIT-V 5.8	400	400	400	400	400	400	400	400	400	400	400
	HIT-V 8.8	640	640	640	640	640	640	640	640	640	640	640
	AM 8.8 [N/mm <sup>2</sup> ]	640	640	640	640	640	640	640	640	640	640	640
	HIT-V-R	450	450	450	450	450	450	210	210	210	210	210
	HIT-V-HCR	640	640	640	640	640	400	400	400	250	250	250
Stressed cross-section $A_s$	HIT-V AM 8.8 [mm <sup>2</sup> ]	36,6	58,0	84,3	157	245	353	459	561	694	817	976
Moment of resistance $W$	HIT-V AM 8.8 [mm <sup>3</sup> ]	31,2	62,3	109	277	541	935	1387	1874	2579	3294	4301

### Material quality

Part	Material
Threaded rod HIT-V 5.8	Strength class 5.8, A5 > 8% ductile Electroplated zinc coated $\geq 5\mu\text{m}$ Hot dip galvanized $\geq 45\mu\text{m}$
Threaded rod HIT-V 8.8	Strength class 8.8, A5 > 12% ductile Electroplated zinc coated $\geq 5\mu\text{m}$ Hot dip galvanized $\geq 45\mu\text{m}$
Hilti Meter rod AM 8.8	Strength class 8.8, A5 > 12% ductile Electroplated zinc coated $\geq 5\mu\text{m}$
Threaded rod HIT-V-R	Strength class 70 for $\leq M24$ and class 50 for $> M24$ , A5 > 8% ductile Stainless steel 1.4401; 1.4404; 1.4578; 1.4571; 1.4439; 1.4362
Threaded rod HIT-V-HCR	Strength class 70 for $\leq M24$ and class 50 for $> M24$ , A5 > 8% ductile High corrosion resistance steel 1.4528; 1.4565;
Washer	Electroplated zinc coated $\geq 5\mu\text{m}$ , hot dip galvanized $\geq 45\mu\text{m}$
	Stainless steel 1.4401, 1.4404, 1.4578, 1.4571, 1.4439, 1.4362 EN 10088-1:2014
	High corrosion resistant steel 1.4529, 1.4565 EN 10088-1:2014
Nut	Strength class of nut adapted to strength class of threaded rod. Electroplated zinc coated $\geq 5\mu\text{m}$ , hot dip galvanized $\geq 45\mu\text{m}$
	Strength class of nut adapted to strength class of threaded rod. Stainless steel 1.4401, 1.4404, 1.4578, 1.4571, 1.4439, 1.4362 EN 10088-1:2014
	Strength class of nut adapted to strength class of threaded rod. High corrosion resistant steel 1.4529, 1.4565 EN 10088-1:2014

### Materials of Hilti seismic filling set

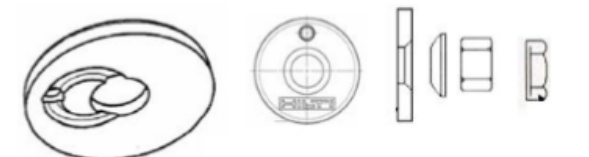
Part	Material	
Filling washer	Electroplated zinc coated $\geq 5\mu\text{m}$	
Spherical washer		
Lock nut		

## Service temperature range

Hilti HIT-RE 500 V3 injection mortar may be applied in the temperature ranges given below. An elevated base material temperature may lead to a reduction of the design bond resistance.

Temperature range	Base material temperature	Maximum long term base material temperature	Maximum short term base material temperature
Temperature range I	-40 °C to +40 °C	+24 °C	+40 °C
Temperature range II	-40 °C to +70 °C	+43 °C	+70 °C

### Max short term base material temperature

Short-term elevated base material temperatures are those that occur over brief intervals, e.g. as a result of diurnal cycling.

### Max long term base material temperature

Long-term elevated base material temperatures are roughly constant over significant periods of time.







## Setting

### Installation equipment

Anchor size	M8	M10	M12	M16	M20	M24	M27	M30
Rotary hammer	TE 2 – TE 16				TE 40 – TE 80			
Other tools	compressed air gun, set of cleaning brushes, dispenser, roughening tools TE-YRT							
<b>Additional Hilti recommended tools</b>	DD EC-1, DD 100 ... DD 160 <sup>a)</sup>							

a) For anchors in diamond drilled holes load values for combined pull-out and concrete cone resistance have to be reduced (see section "Static and quasi-static resistance (for a single anchor)).

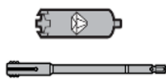
### Parameters of cleaning and setting tools

Threaded rod HIT-V-, AM 8.8	Drill bit diameters $d_0$ [mm]				Installation	
	Hammer drill (HD)	Hollow Drill Bit (HDB)	Diamond coring		Brush HIT-RB	Piston plug HIT-SZ
			Diamond coring (DD)	With roughening tool (RT)		
						
<b>M8</b>	10	-	10	-	10	-
<b>M10</b>	12	-	12	-	12	12
<b>M12</b>	14	14	14	-	14	14
<b>M16</b>	18	18	18	18	18	18
<b>M20</b>	22	22	22	22	22	22
<b>M24</b>	28	28	28	28	28	28
<b>M27</b>	30	-	30	30	30	30
<b>M30</b>	35	35	35	35	35	35

**Associated components for the use of Hilti Roughening tool TE-YRT**

Diamond coring		Roughening tool TE-YRT	Wear gauge RTG...
d <sub>0</sub> [mm]		d <sub>0</sub> [mm]	size
Nominal	measured		
18	17,9 to 18,2	18	18
20	19,9 to 20,2	20	20
22	21,9 to 22,2	22	22
25	24,9 to 25,2	25	25
28	27,9 to 28,2	28	28
30	29,9 to 30,2	30	30
32	31,9 to 32,2	32	32
35	34,9 to 35,2	35	35

**Minimum roughening time t<sub>roughen</sub> (t<sub>roughen</sub> [sec] = h<sub>ef</sub> [mm] /10)**

h <sub>ef</sub> [mm]	t <sub>roughen</sub> [sec]
0 to 100	10
101 to 200	20
201 to 300	30
301 to 400	40
401 to 500	50
501 to 600	60

**Setting instructions**

**Bore hole drilling**

**a) Hammer drilling:** For dry and wet concrete and installation in flooded holes (no sea water).

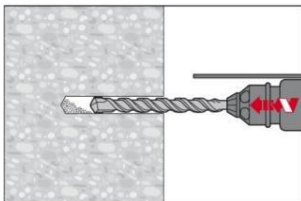

Drill Hole to the required embedment depth with a hammer drill set in rotation-hammer mode using an appropriately sized carbide drill bit.

**b) Hammer drilling with Hilti hollow drill bit:** For dry and wet concrete only.

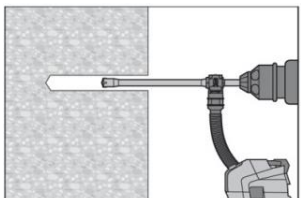

Drill hole to the required embedment depth with an appropriately sized Hilti TE-CD or TE-YD hollow drill bit with Hilti vacuum attachment. This drilling system removes the dust and cleans the bore hole during drilling when used in accordance with the user's manual. After drilling is complete, proceed to the "injection preparation" step in the installation instruction.

**c) Diamond coring:** For dry and wet concrete only.

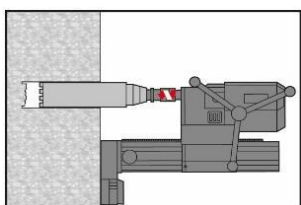

Diamond coring is permissible when suitable diamond core drilling machines and the corresponding core bits are used.

**d) Diamond coring with Hilti roughening tool TE-YRT:** For dry and wet concrete only.

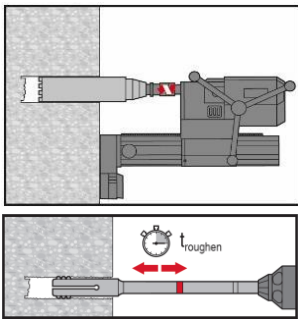

Diamond coring is permissible when suitable diamond core drilling machines and the corresponding core bits are used.

Before roughening the borehole needs to be dry. Check usability of the roughening tool with the wear gauge RTG.

Roughen the borehole over the whole length to the required  $h_{ef}$ .

**Drill hole cleaning**

Just before setting an anchor, the drill hole must be free of dust and debris.

Inadequate hole cleaning=poor load values.

**a) Compressed air cleaning (CAC):** For all drill hole diameters  $d_0$  and all drill hole depths  $h_0$ .

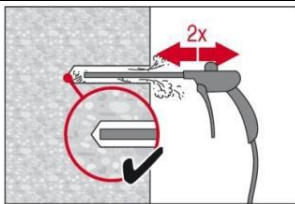

Blow 2 times from the back of the hole (if needed with nozzle extension) over the whole length with oil-free compressed air (min. 6 bar at 6 m<sup>3</sup>/h) until return air stream is free of noticeable dust.

For drill hole diameters  $\geq 32$  mm compressor has to supply a min. air flow of 140 m<sup>3</sup>/h.

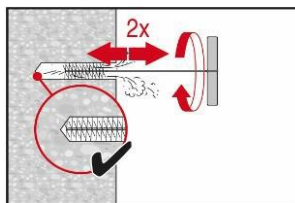

Brush 2 times with the specified brush by inserting the steel brush Hilti HIT-RB to the back of the hole (if needed with extension) in a twisting motion and removing it.

The brush must produce natural resistance as it enters the drill hole (brush  $\varnothing \geq$  drill hole  $\varnothing$ ) - if not the brush is too small and must be replaced with the proper brush diameter.

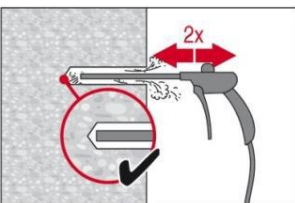

Blow again with compressed air 2 times until return air stream is free of noticeable dust.

**b) Cleaning for under water:** For all bore hole diameters  $d_0$  and all bore hole depth  $h_0$ .

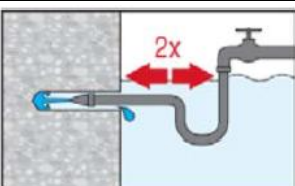

Flush 2 times the hole by inserting a water hose (water-line pressure) to the back of the hole until water runs clear.

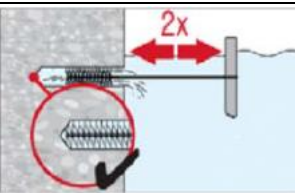

Brush 2 times with the specified brush size by inserting the steel brush Hilti HIT-RB to the back of the hole (if needed with extension) in a twisting motion and removing it.

The brush must produce natural resistance as it enters the bore hole - if not the brush is too small and must be replaced with the proper brush diameter.

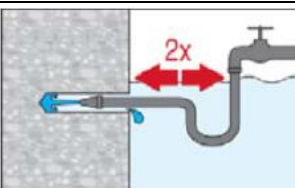

Flush again 2 times the hole by inserting a water hose (water-line pressure) to the back of the hole until water runs clear.

**c) Cleaning of hammer drilled holes and diamond cored holes:** For all bore hole diameters  $d_0$  and all bore hole depth  $h_0$

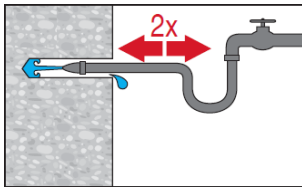

Flush 2 times the hole by inserting a water hose (water-line pressure) to the back of the hole until water runs clear.

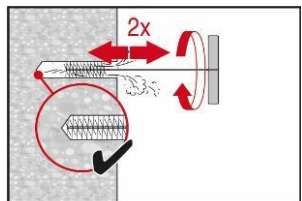

Brush 2 times with the specified brush by inserting the steel brush Hilti HIT-RB to the back of the hole (if needed with extension) in a twisting motion and removing it. The brush must produce natural resistance as it enters the bore hole - if not the brush is too small and must be replaced with the proper brush diameter.

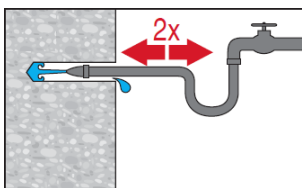

Flush 2 times by inserting a water hose (water-line pressure) to the back of the hole until water runs clear.

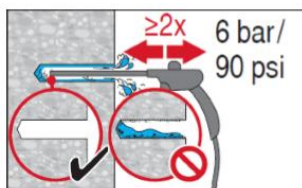

Blow 2 times from the back of the hole (if needed with nozzle extension) over the hole length with oil-free compressed air (min. 6 bar at 6 m<sup>3</sup>/h) until return air stream is free of noticeable dust and water.

For drill hole diameter  $\geq 32$  mm the compressor must supply a minimum air flow of 140 m<sup>3</sup>/hour.

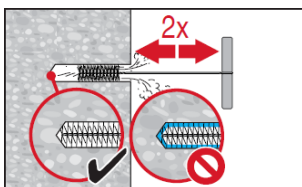

Brush 2 times with the specified brush size by inserting the steel brush Hilti HIT-RB to the back of the hole (if needed with extension) in a twisting motion and removing it.

The brush must produce natural resistance as it enters the bore hole - if not the brush is too small and must be replaced with the proper brush diameter.

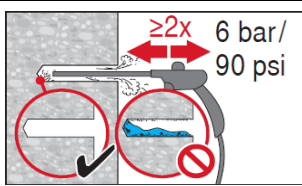

Blow again with compressed air 2 times until return air stream is free of noticeable dust and water.

**d) Cleaning of diamond cored holes with Hilti roughening tool TE-YRT:** For all drill hole diameters  $d_0$  and all drill hole depths  $h_0$ .

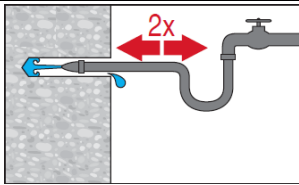

Flush 2 times by inserting a water hose (water-line pressure) to the back of the hole until water runs clear.

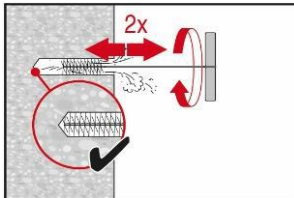

Brush 2 times with the specified brush by inserting the steel brush Hilti HIT-RB to the back of the hole (if needed with extension) in a twisting motion and removing it. The brush must produce natural resistance as it enters the drill hole (brush  $\varnothing \geq$  drill hole  $\varnothing$ ) - if not the brush is too small and must be replaced with the proper brush diameter.

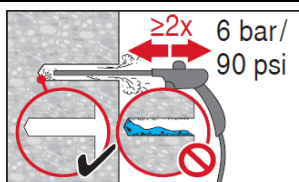

Blow 2 times from the back of the hole (if needed with nozzle extension) over the whole length with oil-free compressed air (min. 6 bar at 6 m<sup>3</sup>/h) until return air stream is free of noticeable dust and water. For drill hole diameters  $\geq$  32 mm the compressor has to supply a minimum air flow of 140 m<sup>3</sup>/h.

**Injection preparation**

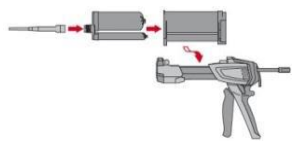

Tightly attach new Hilti mixing nozzle HIT-RE-M to foil pack manifold. Do not modify the mixing nozzle.  
Observe the instruction for use of the dispenser and mortar.  
Check foil pack holder for proper function.  
Insert foil pack into foil pack holder and put holder into dispenser.

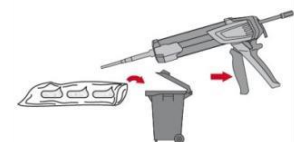

The foil pack opens automatically as dispensing is initiated. Discard initial adhesive. Depending on the size of the foil pack an initial amount of adhesive has to be discarded.  
Discard quantities are: 3 strokes for 330 ml foil pack, 4 strokes for 500 ml foil pack, 65 ml for 1400 ml foil pack.

**Inject adhesive from the back of the drill hole without forming air voids.**

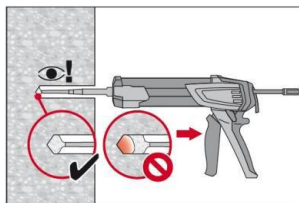

Inject the adhesive starting at the back of the hole, slowly withdrawing the mixer with each trigger pull.  
Fill holes approximately 2/3 full. It is required that the annular gap between the anchor and the concrete is completely filled with adhesive along the embedment length.

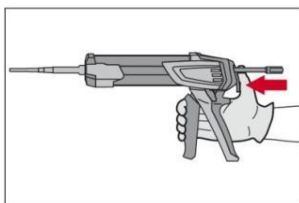

After injection is completed, depressurize the dispenser by pressing the release trigger. This will prevent further adhesive discharge from the mixer.

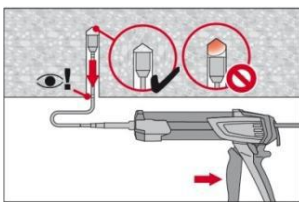

Overhead installation and/or installation with embedment depth  $h_{ef} > 250$ mm.  
For overhead installation the injection is only possible with the aid of extensions and piston plugs. Assemble HIT-RE-M mixer, extension(s) and appropriately sized piston plug HIT-SZ. Insert piston plug to back of the hole and inject adhesive. During injection the piston plug will be naturally extruded out of the bore hole by the adhesive pressure.

**Setting the element:** Just before setting an anchor, the drill hole must be free of dust and debris.

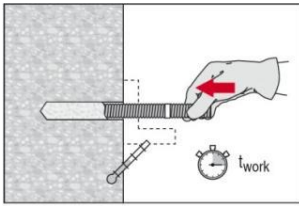

Before use, verify that the element is dry and free of oil and other contaminants. Mark and set element to the required embedment depth before working time  $t_{work}$  has elapsed.

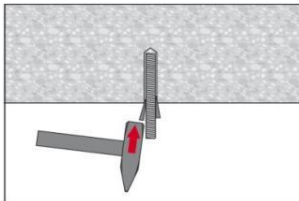

For overhead installation use piston plugs and fix embedded parts with e.g. wedges.

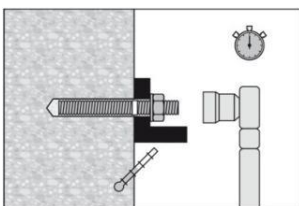

Loading the anchor: after required curing time  $t_{cure}$  the anchor can be loaded. The applied installation torque shall not exceed  $T_{max}$ .

**Installation with Seismic filling set (HIT-V and AM 8.8)**

<p><b>1</b></p> <p>HIT-V 8.8 / AM 8.8</p>	<p><b>1a</b></p>
<p><b>2</b></p>	<p><b>3</b></p>
<p><b>4</b></p> <p>HIT-V 8.8 / AM 8.8</p>	<p><b>5</b></p>
<p><b>6</b></p> <p><math>\frac{1}{4} - \frac{1}{2}</math></p> <p><math>t_{fix, effective}</math></p>	<p><b>7</b></p> <p>HIT-HY 200-A/-R HIT-RE500V3</p>
<p><b>8</b></p> <p>1-3</p>	<p><b>9</b></p> <p><math>T_{cure}</math></p> <p>HIT-HY200-A/-R HIT-RE500V3</p>

For detailed information on installation see instruction for use given with the package of the product.

**Curing time for general conditions**

Temperature of the base material T	Working time t <sub>work</sub>	Minimum curing time t <sub>cure</sub> <sup>1)</sup>
-5 °C to -1 °C	2 h	168 h
0 °C to 4 °C	2 h	48 h
5 °C to 9 °C	2 h	24 h
10 °C to 14 °C	1,5 h	16 h
15 °C to 19 °C	1 h	16 h
20 °C to 24 °C	30 min	7 h
25 °C to 29 °C	20 min	6 h
30 °C to 34 °C	15 min	5 h
35 °C to 39 °C	12 min	4,5 h
40 °C	10 min	4 h

1) The curing time data are valid for dry base material only. In wet base material the curing times must be doubled.

**Setting details**

Anchor size		ETA-16/0143, issue 2016-11-30								Additional Hilti Technical data		
		M8	M10	M12	M16	M20	M24	M27	M30	M33	M36	M39
Nominal diameter of drill bit	d <sub>0</sub> [mm]	10	12	14	18	22	28	30	35	37	40	42
Effective anchorage and drill hole depth range <sup>a)</sup>	h <sub>ef,min</sub> [mm]	60	60	70	80	90	96	108	120	132	144	156
	h <sub>ef,max</sub> [mm]	160	200	240	320	400	480	540	600	660	720	780
Minimum base material thickness	h <sub>min</sub> [mm]	h <sub>ef</sub> + 30 mm ≥ 100 mm				h <sub>ef</sub> + 2 d <sub>0</sub>						
Maximum torque moment	T <sub>max</sub> [Nm]	10	20	40	80	150	200	270	300	330	360	390
Minimum spacing	s <sub>min</sub> [mm]	40	50	60	75	90	115	120	140	165	180	195
Minimum edge distance	c <sub>min</sub> [mm]	40	45	45	50	55	60	75	80	165	180	195
Critical spacing for splitting failure	s <sub>cr,sp</sub>	2 c <sub>cr,sp</sub>										
Critical edge distance for splitting failure <sup>b)</sup>	c <sub>cr,sp</sub> [mm]	1,0 · h <sub>ef</sub> for h / h <sub>ef</sub> ≥ 2,0										
		4,6 h <sub>ef</sub> - 1,8 h for 2,0 > h / h <sub>ef</sub> > 1,3										
		2,26 h <sub>ef</sub> for h / h <sub>ef</sub> ≤ 1,3										
Critical spacing for concrete cone failure	s <sub>cr,N</sub>	2 c <sub>cr,N</sub>										
Critical edge distance for concrete cone failure <sup>c)</sup>	c <sub>cr,N</sub>	1,5 h <sub>ef</sub>										

For spacing (edge distance) smaller than critical spacing (critical edge distance) the design loads have to be reduced.

- a)  $h_{ef,min} \leq h_{ef} \leq h_{ef,max}$  (h<sub>ef</sub>: embedment depth)
- b) h: base material thickness (h ≥ h<sub>min</sub>)
- c) The critical edge distance for concrete cone failure depends on the embedment depth h<sub>ef</sub> and the design bond resistance. The simplified formula given in this table is on the safe side.

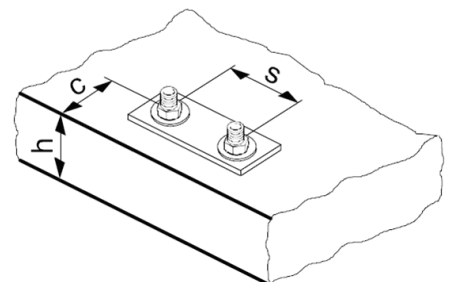

## Simplified design method

Simplified version of the design method according ETAG 001.

- Influence of concrete strength
- Influence of edge distance
- Influence of spacing
- Valid for a group of two anchors. The method may also be applied for anchor groups with more than two anchors or more than one edge distance. The influencing factors must then be considered for each edge distance and spacing.

The design method is based on the following simplification:

- No different loads are acting on individual anchors (no eccentricity)

The values are valid for one anchor.

## Tension loading

### The design tensile resistance is the lower value of

- Steel resistance:  $N_{Rd,s}$
- Combined pull-out and concrete cone resistance:  
 $N_{Rd,p} = N_{Rd,p}^0 \cdot f_{B,p} \cdot f_{1,N} \cdot f_{2,N} \cdot f_{3,N} \cdot f_{h,p} \cdot f_{re,N}$
- Concrete cone resistance:  $N_{Rd,c} = N_{Rd,c}^0 \cdot f_B \cdot f_{1,N} \cdot f_{2,N} \cdot f_{3,N} \cdot f_{h,N} \cdot f_{re,N}$
- Concrete splitting resistance (only non-cracked concrete):  
 $N_{Rd,sp} = N_{Rd,c}^0 \cdot f_B \cdot f_{1,sp} \cdot f_{2,sp} \cdot f_{3,sp} \cdot f_{h,N} \cdot f_{re,N}$

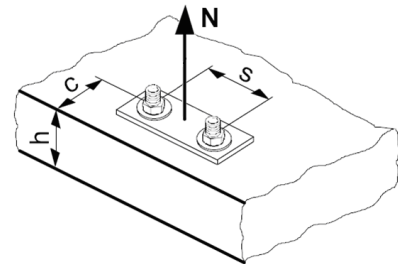

### Design steel resistance $N_{Rd,s}$

Anchor size		ETA-16/0143, issue 2016-11-30							Additional Hilti technical data			
		M8	M10	M12	M16	M20	M24	M27	M30	M33	M36	M39
$N_{Rd,s}$ [kN]	HIT-V 5.8	12,0	19,3	28,0	52,7	82,0	118,0	153,3	187,3	231,3	272,7	325,3
	HIT-V 8.8, AM 8.8	19,3	30,7	44,7	84,0	130,7	188,0	244,7	299,3	370,0	436,0	520,7
	HIT-V-R	13,9	21,9	31,6	58,8	92,0	132,1	80,4	98,3	121,3	143,0	170,6
	HIT-V-HCR	19,3	30,7	44,7	84,0	130,7	117,6	152,9	187,1	144,6	170,4	203,3

**Design combined pull-out and concrete cone resistance for anchors**

$$N_{Rd,p} = N_{Rd,p}^0 \cdot f_{B,p} \cdot f_{1,N} \cdot f_{2,N} \cdot f_{3,N} \cdot f_{h,p} \cdot f_{re,N}$$

Anchor size			ETA-16/0143, issue 2016-11-30							Additional Hilti technical data			
			M8	M10	M12	M16	M20	M24	M27	M30	M33	M36	M39
Typical embedment depth $h_{ef,typ}$ [mm]			80	90	110	125	170	210	240	270	300	330	360
Hammer drilling + Hilti hollow drill bit	$N_{Rd,p}^0$ [kN]	Temp range I	24,1	33,9	47,0	67,0	106,8	158,3	190,0	220,5	190,1	207,3	245,0
	$N_{Rd,p}^0$ [kN]	Temp range II	18,8	24,5	35,9	50,3	85,5	116,1	135,7	169,6	155,5	176,2	196,0
Diamond coring	$N_{Rd,p}^0$ [kN]	Temp range I	13,4	18,8	27,6	35,9	61,0	82,9	106,6	133,3	-	-	-
	$N_{Rd,p}^0$ [kN]	Temp range II	10,6	14,1	20,7	26,9	45,8	64,1	82,4	103,0	-	-	-

**Design concrete cone resistance**  $N_{Rd,c} = N_{Rd,c}^0 \cdot f_B \cdot f_{1,N} \cdot f_{2,N} \cdot f_{3,N} \cdot f_{h,N} \cdot f_{re,N}$

**Design splitting resistance**  $N_{Rd,sp} = N_{Rd,c}^0 \cdot f_B \cdot f_{1,sp} \cdot f_{2,sp} \cdot f_{3,sp} \cdot f_{h,N} \cdot f_{re,N}$

Anchor size			ETA-16/0143, issue 2016-11-30							Additional Hilti technical data			
			M8	M10	M12	M16	M20	M24	M27	M30	M33	M36	M39
$N_{Rd,c}^0$	[kN]		24,1	28,7	38,8	47,1	74,6	102,5	125,2	149,4	145,8	168,2	191,6

**Influencing factors**
**Influence of concrete strength on combined pull-out and concrete cone resistance**

Concrete strength designation (ENV 206)	C 20/25	C 25/30	C 30/37	C 35/45	C 40/50	C 45/55	C 50/60
$f_{B,p} = (f_{ck,cube}/25N/mm^2)^{0,1}$ a)	1	1,02	1,04	1,06	1,07	1,08	1,09

a)  $f_{ck,cube}$  = concrete compressive strength, measured on cubes with 150 mm side length

**Influence of embedment depth on combined pull-out and concrete cone resistance**

$$f_{h,p} = h_{ef}/h_{ef,typ}$$

**Influence of concrete strength on concrete cone resistance**

Concrete strength designation (ENV 206)	C 20/25	C 25/30	C 30/37	C 35/45	C 40/50	C 45/55	C 50/60
$f_B = (f_{ck,cube}/25N/mm^2)^{1/2}$ a)	1	1,1	1,22	1,34	1,41	1,48	1,55

a)  $f_{ck,cube}$  = concrete compressive strength, measured on cubes with 150 mm side length

**Influence of edge distance <sup>a)</sup>**

$c/c_{cr,N}$	0,1	0,2	0,3	0,4	0,5	0,6	0,7	0,8	0,9	1
$c/c_{cr,sp}$										
$f_{1,N} = 0,7 + 0,3 \cdot c/c_{cr,N}$	0,73	0,76	0,79	0,82	0,85	0,88	0,91	0,94	0,97	1
$f_{1,sp} = 0,7 + 0,3 \cdot c/c_{cr,sp}$										
$f_{2,N} = 0,5 \cdot (1 + c/c_{cr,N})$	0,55	0,60	0,65	0,70	0,75	0,80	0,85	0,90	0,95	1
$f_{2,sp} = 0,5 \cdot (1 + c/c_{cr,sp})$										

a) The edge distance shall not be smaller than the minimum edge distance  $c_{min}$  given in the table with the setting details. These influencing factors must be considered for every edge distance smaller than the critical edge distance.

**Influence of anchor spacing <sup>a)</sup>**

$s/s_{cr,N}$	0,1	0,2	0,3	0,4	0,5	0,6	0,7	0,8	0,9	1
$s/s_{cr,sp}$										
$f_{3,N} = 0,5 \cdot (1 + s/s_{cr,N})$	0,55	0,60	0,65	0,70	0,75	0,80	0,85	0,90	0,95	1
$f_{3,sp} = 0,5 \cdot (1 + s/s_{cr,sp})$										

a) The anchor spacing shall not be smaller than the minimum anchor spacing  $s_{min}$  given in the table with the setting details. This influencing factor must be considered for every anchor spacing.

**Influence of embedment depth on concrete cone resistance:  $f_{h,N} = (h_{ef}/h_{ef,typ})^{1,5}$** 
**Influence of reinforcement**

$h_{ef}$ [mm]	40	50	60	70	80	90	$\geq 100$
$f_{re,N} = 0,5 + h_{ef}/200mm \leq 1$	0,7 <sup>a)</sup>	0,75 <sup>a)</sup>	0,8 <sup>a)</sup>	0,85 <sup>a)</sup>	0,9 <sup>a)</sup>	0,95 <sup>a)</sup>	1

a) This factor applies only for dense reinforcement. If in the area of anchorage there is reinforcement with a spacing  $\geq 150$  mm (any diameter) or with a diameter  $\leq 10$  mm and a spacing  $\geq 100$  mm, then a factor  $f_{re} = 1$  may be applied.

**Shear loading**
**The design shear resistance is the lower value of**

- Steel resistance:  $V_{Rd,s}$
- Concrete pryout resistance:  $V_{Rd,cp} = k \cdot \text{lower value of } N_{Rd,p} \text{ and } N_{Rd,c}$
- Concrete edge resistance:  $V_{Rd,c} = V_{Rd,c}^0 \cdot f_B \cdot f_{B'} \cdot f_h \cdot f_4 \cdot f_{hef} \cdot f_c$

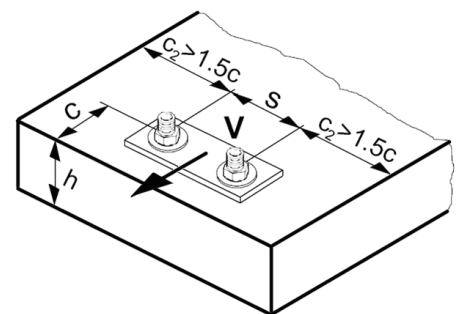
**Design steel resistance  $V_{Rd,s}$** 

Anchor size	ETA-16/0143, issue 2016-11-30								Additional Hilti technical data		
	M8	M10	M12	M16	M20	M24	M27	M30	M33	M36	M39
$V_{Rd,s}$ HIT-V 5.8	7,2	12,0	16,8	31,2	48,8	70,4	92,0	112,0	139,2	163,2	195,2
HIT-V 8.8, AM 8.8	12,0	18,4	27,2	50,4	78,4	112,8	147,2	179,2	222,4	261,6	312,0
HIT-V-R	8,3	12,8	19,2	35,3	55,1	79,5	48,3	58,8	73,1	85,7	102,5
HIT-V-HCR	12,0	18,4	27,2	50,4	78,4	70,9	92,0	112,0	87,0	102,0	122,0

Design concrete pryout resistance  $V_{Rd,cp} = \text{lower value}^a$  of  $k \cdot N_{Rd,p}$  and  $k \cdot N_{Rd,c}$

$k = 1$  for  $h_{ef} < 60$  mm

$k = 2$  for  $h_{ef} \geq 60$  mm

- a)  $N_{Rd,p}$ : Design combined pull-out and concrete cone resistance  
 $N_{Rd,c}$ : Design concrete cone resistance

Design concrete edge resistance  $V_{Rd,c} = V_{Rd,c}^0 \cdot f_B \cdot f_{\beta} \cdot f_h \cdot f_4 \cdot f_{hef} \cdot f_c$

Anchor size	M8	M10	M12	M16	M20	M24	M27	M30	M33	M36	M39
<b>Non-cracked concrete</b>											
$V_{Rd,c}^0$ [kN]	5,9	8,6	11,6	18,7	27,0	36,6	44,5	53,0	62,1	71,7	81,9

### Influencing factors

#### Influence of concrete strength

Concrete strength designation (ENV 206)	C 20/25	C 25/30	C 30/37	C 35/45	C 40/50	C 45/55	C 50/60
$f_B = (f_{ck,cube}/25N/mm^2)^{1/2}$ a)	1	1,1	1,22	1,34	1,41	1,48	1,55

- a)  $f_{ck,cube}$  = concrete compressive strength, measured on cubes with 150 mm side length

#### Influence of angle between load applied and the direction perpendicular to the free edge

Angle $\beta$	0°	10°	20°	30°	40°	50°	60°	70°	80°	≥ 90°
$f_{\beta} = \frac{1}{\sqrt{(\cos \alpha_V)^2 + \left(\frac{\sin \alpha_V}{2,5}\right)^2}}$	1	1,01	1,05	1,13	1,24	1,40	1,64	1,97	2,32	2,50

#### Influence of base material thickness

$h/c$	0,15	0,3	0,45	0,6	0,75	0,9	1,05	1,2	1,35	≥ 1,5
$f_h = \{h/(1,5 \cdot c)\}^{1/2} \leq 1$	0,32	0,45	0,55	0,63	0,71	0,77	0,84	0,89	0,95	1,00

**Influence of anchor spacing and edge distance <sup>a)</sup> for concrete edge resistance:  $f_4$** 

$$f_4 = (c/h_{ef})^{1,5} \cdot (1 + s / [3 \cdot c]) \cdot 0,5$$

c/h <sub>ef</sub>	Single anchor	Group of two anchors s/h <sub>ef</sub>														
		0,75	1,50	2,25	3,00	3,75	4,50	5,25	6,00	6,75	7,50	8,25	9,00	9,75	10,50	11,25
0,50	0,35	0,27	0,35	0,35	0,35	0,35	0,35	0,35	0,35	0,35	0,35	0,35	0,35	0,35	0,35	0,35
0,75	0,65	0,43	0,54	0,65	0,65	0,65	0,65	0,65	0,65	0,65	0,65	0,65	0,65	0,65	0,65	0,65
1,00	1,00	0,63	0,75	0,88	1,00	1,00	1,00	1,00	1,00	1,00	1,00	1,00	1,00	1,00	1,00	1,00
1,25	1,40	0,84	0,98	1,12	1,26	1,40	1,40	1,40	1,40	1,40	1,40	1,40	1,40	1,40	1,40	1,40
1,50	1,84	1,07	1,22	1,38	1,53	1,68	1,84	1,84	1,84	1,84	1,84	1,84	1,84	1,84	1,84	1,84
1,75	2,32	1,32	1,49	1,65	1,82	1,98	2,15	2,32	2,32	2,32	2,32	2,32	2,32	2,32	2,32	2,32
2,00	2,83	1,59	1,77	1,94	2,12	2,30	2,47	2,65	2,83	2,83	2,83	2,83	2,83	2,83	2,83	2,83
2,25	3,38	1,88	2,06	2,25	2,44	2,63	2,81	3,00	3,19	3,38	3,38	3,38	3,38	3,38	3,38	3,38
2,50	3,95	2,17	2,37	2,57	2,77	2,96	3,16	3,36	3,56	3,76	3,95	3,95	3,95	3,95	3,95	3,95
2,75	4,56	2,49	2,69	2,90	3,11	3,32	3,52	3,73	3,94	4,15	4,35	4,56	4,56	4,56	4,56	4,56
3,00	5,20	2,81	3,03	3,25	3,46	3,68	3,90	4,11	4,33	4,55	4,76	4,98	5,20	5,20	5,20	5,20
3,25	5,86	3,15	3,38	3,61	3,83	4,06	4,28	4,51	4,73	4,96	5,18	5,41	5,63	5,86	5,86	5,86
3,50	6,55	3,51	3,74	3,98	4,21	4,44	4,68	4,91	5,14	5,38	5,61	5,85	6,08	6,31	6,55	6,55
3,75	7,26	3,87	4,12	4,36	4,60	4,84	5,08	5,33	5,57	5,81	6,05	6,29	6,54	6,78	7,02	7,26
4,00	8,00	4,25	4,50	4,75	5,00	5,25	5,50	5,75	6,00	6,25	6,50	6,75	7,00	7,25	7,50	7,75
4,25	8,76	4,64	4,90	5,15	5,41	5,67	5,93	6,18	6,44	6,70	6,96	7,22	7,47	7,73	7,99	8,25
4,50	9,55	5,04	5,30	5,57	5,83	6,10	6,36	6,63	6,89	7,16	7,42	7,69	7,95	8,22	8,49	8,75
4,75	10,35	5,45	5,72	5,99	6,27	6,54	6,81	7,08	7,36	7,63	7,90	8,17	8,45	8,72	8,99	9,26
5,00	11,18	5,87	6,15	6,43	6,71	6,99	7,27	7,55	7,83	8,11	8,39	8,66	8,94	9,22	9,50	9,78
5,25	12,03	6,30	6,59	6,87	7,16	7,45	7,73	8,02	8,31	8,59	8,88	9,17	9,45	9,74	10,02	10,31
5,50	12,90	6,74	7,04	7,33	7,62	7,92	8,21	8,50	8,79	9,09	9,38	9,67	9,97	10,26	10,55	10,85

a) The anchor spacing and the edge distance shall not be smaller than the minimum anchor spacing  $s_{min}$  and the minimum edge distance  $c_{min}$ .

**Influence of embedment depth**

h <sub>ef</sub> /d	4	4,5	5	6	7	8	9	10	11
$f_{hef} = 0,05 \cdot (h_{ef} / d)^{1,68}$	0,51	0,63	0,75	1,01	1,31	1,64	2,00	2,39	2,81
h <sub>ef</sub> /d	12	13	14	15	16	17	18	19	20
$f_{hef} = 0,05 \cdot (h_{ef} / d)^{1,68}$	3,25	3,72	4,21	4,73	5,27	5,84	6,42	7,04	7,67

**Influence of edge distance <sup>a)</sup>**

c/d	4	6	8	10	15	20	30	40
$f_c = (d / c)^{0,19}$	0,77	0,71	0,67	0,65	0,60	0,57	0,52	0,50

a) The edge distance shall not be smaller than the minimum edge distance  $c_{min}$ .

**Combined tension and shear loading for hammer drilling or Hilti hollow drill bit**
**Precalculated values**

Recommended loads can be calculated by dividing the design resistance by an overall partial safety factor for action  $\gamma = 1,4$ . The partial safety factors for action depend on the type of loading and shall be taken from national regulations.

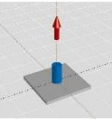
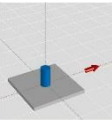

**Design resistance: concrete C 20/25 –  $f_{ck,cube} = 25 \text{ N/mm}^2$ , Temperature range I**

Anchor size	ETA-16/0143, issue 2016-11-30								Additional Hilti technical data			
	M8	M10	M12	M16	M20	M24	M27	M30	M33	M36	M39	
Embedment depth $h_{ef,1} =$ [mm]	60	60	70	80	90	96	108	120	132	144	156	
Base material thickness $h_{min} =$ [mm]	100	100	100	116	134	152	168	190	206	224	240	
<b>Tensile <math>N_{Rd}</math>: single anchor, no edge effects</b>												
 HIT-V 5.8 HIT-V 8.8, AM 8.8 HIT-V-R HIT-V-HCR	[kN]	12,0	15,6	19,7	24,1	28,7	31,7	37,8	44,3	42,5	48,5	54,7
		15,6	15,6	19,7	24,1	28,7	31,7	37,8	44,3	42,5	48,5	54,7
		13,9	15,6	19,7	24,1	28,7	31,7	37,8	44,3	42,5	48,5	54,7
		15,6	15,6	19,7	24,1	28,7	31,7	37,8	44,3	42,5	48,5	54,7
<b>Shear <math>V_{Rd}</math>: single anchor, no edge effects, without lever arm</b>												
 HIT-V 5.8 HIT-V 8.8, AM 8.8 HIT-V-R HIT-V-HCR	[kN]	7,2	12,0	16,8	31,2	48,8	63,3	75,6	88,5	102,1	116,4	131,2
		12,0	18,4	27,2	48,2	57,5	63,3	75,6	88,5	102,1	116,4	131,2
		8,3	12,8	19,2	35,3	55,1	63,3	48,3	58,8	73,1	85,7	102,5
		12,0	18,4	27,2	48,2	57,5	63,3	75,6	88,5	87,0	102,0	122,0

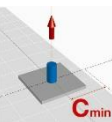
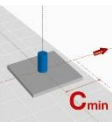
**Design resistance: concrete C 20/25 –  $f_{ck,cube} = 25 \text{ N/mm}^2$ , Temperature range I**

Anchor size	ETA-16/0143, issue 2016-11-30								Additional Hilti technical data			
	M8	M10	M12	M16	M20	M24	M27	M30	M33	M36	M39	
Embedment depth $h_{ef,1} =$ [mm]	60	60	70	80	90	96	108	120	132	144	156	
Base material thickness $h_{min} =$ [mm]	100	100	100	116	134	152	168	190	206	224	240	
Edge distance $c = c_{min} =$ [mm]	40	45	45	50	55	60	75	80	165	180	195	
<b>Tensile <math>N_{Rd}</math>: single anchor, min. edge distance (<math>c = c_{min}</math>)</b>												
 HIT-V 5.8 HIT-V 8.8, AM 8.8 HIT-V-R HIT-V-HCR	[kN]	9,1	9,7	10,3	12,6	15,1	17,3	21,4	24,9	32,8	37,3	41,6
		9,1	9,7	10,3	12,6	15,1	17,3	21,4	24,9	32,8	37,3	41,6
		9,1	9,7	10,3	12,6	15,1	17,3	21,4	24,9	32,8	37,3	41,6
		9,1	9,7	10,3	12,6	15,1	17,3	21,4	24,9	32,8	37,3	41,6
<b>Shear <math>V_{Rd}</math>: single anchor, min. edge distance (<math>c = c_{min}</math>), without lever arm</b>												
 HIT-V 5.8 HIT-V 8.8, AM 8.8 HIT-V-R HIT-V-HCR	[kN]	3,5	4,3	4,6	5,7	6,9	8,1	11,3	12,9	30,1	34,8	39,5
		3,5	4,3	4,6	5,7	6,9	8,1	11,3	12,9	30,1	34,8	39,5
		3,5	4,3	4,6	5,7	6,9	8,1	11,3	12,9	30,1	34,8	39,5
		3,5	4,3	4,6	5,7	6,9	8,1	11,3	12,9	30,1	34,8	39,5

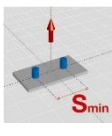
**Design resistance: concrete C 20/25 –  $f_{ck,cube} = 25 \text{ N/mm}^2$ , Temperature range I  
(load values are valid for single anchor)**

Anchor size	ETA-16/0143, issue 2016-11-30								Additional Hilti technical data		
	M8	M10	M12	M16	M20	M24	M27	M30	M33	M36	M39
Embedment depth $h_{ef,1} =$ [mm]	60	60	70	80	90	96	108	120	132	144	156
Base material thickness $h_{min} =$ [mm]	100	100	100	116	134	152	168	190	206	224	240
Spacing $s = s_{min} =$ [mm]	40	50	60	75	90	115	120	140	165	180	195
<b>Tensile <math>N_{Rd}</math>: double anchor, no edge effects, min. spacing (<math>s = s_{min}</math>)</b>											
 HIT-V 5.8 [kN]	9,5	9,9	11,9	14,9	18,1	21,3	24,7	29,5	28,7	32,7	36,7
HIT-V 8.8, AM 8.8 [kN]											
HIT-V-R [kN]											
HIT-V-HCR [kN]											
<b>Shear <math>V_{Rd}</math>: double anchor, no edge effects, min. spacing (<math>s = s_{min}</math>), without lever arm</b>											
 HIT-V 5.8 [kN]	7,2	12,0	16,8	31,2	38,3	44,3	51,8	61,5	72,3	82,4	92,9
HIT-V 8.8, AM 8.8 [kN]	12,0	18,4	25,4	31,6	38,3	44,3	51,8	61,5	72,3	82,4	92,9
HIT-V-R [kN]	8,3	12,8	19,2	31,6	38,3	44,3	48,3	58,8	72,3	82,4	92,9
HIT-V-HCR [kN]	12,0	18,4	25,4	31,6	38,3	44,3	51,8	61,5	72,3	82,4	92,9

**Design resistance: concrete C 20/25 –  $f_{ck,cube} = 25 \text{ N/mm}^2$ , Temperature range I**

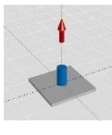
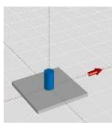
Anchor size	ETA-16/0143, issue 2016-11-30								Additional Hilti technical data		
	M8	M10	M12	M16	M20	M24	M27	M30	M33	M36	M39
Embedment depth $h_{ef,typ} =$ [mm]	80	90	110	125	170	210	240	270	300	330	360
Base material thickness $h_{min} =$ [mm]	110	120	140	161	214	266	300	340	374	410	444
<b>Tensile <math>N_{Rd}</math>: single anchor, no edge effects</b>											
 HIT-V 5.8 [kN]	12,0	19,3	28,0	47,1	74,6	102,5	125,2	149,4	145,8	168,2	191,6
HIT-V 8.8, AM 8.8 [kN]	19,3	28,7	38,8	47,1	74,6	102,5	125,2	149,4	145,8	168,2	191,6
HIT-V-R [kN]	13,9	21,9	31,6	47,1	74,6	102,5	80,4	98,3	121,3	143,0	170,6
HIT-V-HCR [kN]	19,3	28,7	38,8	47,1	74,6	102,5	125,2	149,4	144,6	168,2	191,6
<b>Shear <math>V_{Rd}</math>: single anchor, no edge effects, without lever arm</b>											
 HIT-V 5.8 [kN]	7,2	12,0	16,8	31,2	48,8	70,4	92,0	112,0	138,8	163,4	195,2
HIT-V 8.8, AM 8.8 [kN]	12,0	18,4	27,2	50,4	78,4	112,8	147,2	179,2	222,1	261,4	312,3
HIT-V-R [kN]	8,3	12,8	19,2	35,3	55,1	79,5	48,3	58,8	72,9	85,8	102,5
HIT-V-HCR [kN]	12,0	18,4	27,2	50,4	78,4	70,9	92,0	112,0	86,8	102,1	122,0

**Design resistance: concrete C 20/25 –  $f_{ck,cube} = 25 \text{ N/mm}^2$ , Temperature range I**

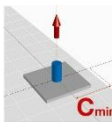
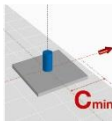
Anchor size	ETA-16/0143, issue 2016-11-30								Additional Hilti technical data		
	M8	M10	M12	M16	M20	M24	M27	M30	M33	M36	M39
Embedment depth $h_{ef,typ} =$ [mm]	80	90	110	125	170	210	240	270	300	330	360
Base material thickness $h_{min} =$ [mm]	110	120	140	161	214	266	300	340	374	410	444
Edge distance $c = c_{min} =$ [mm]	40	45	45	50	55	60	75	80	165	180	195
<b>Tensile <math>N_{Rd}</math>: single anchor, min. edge distance (<math>c = c_{min}</math>)</b>											
 HIT-V 5.8 [kN]	11,5	13,5	17,3	20,9	31,7	42,6	52,8	62,5	70,1	80,6	91,7
HIT-V 8.8, AM 8.8 [kN]											
HIT-V-R [kN]											
HIT-V-HCR [kN]											
<b>Shear <math>V_{Rd}</math>: single anchor, min. edge distance (<math>c = c_{min}</math>), without lever arm</b>											
 HIT-V 5.8 [kN]	3,7	4,7	5,1	6,4	8,4	10,5	14,6	16,9	41,1	47,8	54,9
HIT-V 8.8, AM 8.8 [kN]											
HIT-V-R [kN]											
HIT-V-HCR [kN]											

Design resistance: concrete C 20/25 –  $f_{ck,cube} = 25 \text{ N/mm}^2$ , Temperature range I  
(load values are valid for single anchor)

Anchor size	ETA-16/0143, issue 2016-11-30								Additional Hilti technical data			
	M8	M10	M12	M16	M20	M24	M27	M30	M33	M36	M39	
Embedment depth $h_{ef,typ} =$ [mm]	80	90	110	125	170	210	240	270	300	330	360	
Base material thickness $h_{min} =$ [mm]	110	120	140	161	214	266	300	340	374	410	444	
Spacing $s = s_{min} =$ [mm]	40	50	60	75	90	115	120	140	165	180	195	
<b>Tensile <math>N_{Rd}</math>: double anchor, no edge effects, min. spacing (<math>s = s_{min}</math>)</b>												
	HIT-V 5.8	12,0	16,2	21,8	26,6	41,7	57,4	69,5	83,2	81,8	94,2	107,3
	HIT-V 8.8, AM 8.8	13,5	16,2	21,8	26,6	41,7	57,4	69,5	83,2	81,8	94,2	107,3
	HIT-V-R	13,5	16,2	21,8	26,6	41,7	57,4	69,5	83,2	81,8	94,2	107,3
	HIT-V-HCR	13,5	16,2	21,8	26,6	41,7	57,4	69,5	83,2	81,8	94,2	107,3
<b>Shear <math>V_{Rd}</math>: double anchor, no edge effects, min. spacing (<math>s = s_{min}</math>), without lever arm</b>												
	HIT-V 5.8	7,2	12,0	16,8	31,2	48,8	70,4	92,0	112,0	139,2	163,2	195,2
	HIT-V 8.8, AM 8.8	12,0	18,4	27,2	50,4	78,4	112,8	146,0	175,2	207,0	238,5	271,5
	HIT-V-R	8,3	12,8	19,2	35,3	55,1	79,5	48,3	58,8	73,1	85,7	102,5
	HIT-V-HCR	12,0	18,4	27,2	50,4	78,4	70,9	92,0	112,0	87,0	102,0	122,0

Design resistance: concrete C 20/25 –  $f_{ck,cube} = 25 \text{ N/mm}^2$ , Temperature range I

Anchor size	ETA-16/0143, issue 2016-11-30								Additional Hilti technical data			
	M8	M10	M12	M16	M20	M24	M27	M30	M33	M36	M39	
Embedment depth $h_{ef,2} =$ [mm]	96	120	144	192	240	288	324	360	396	432	468	
Base material thickness $h_{min} =$ [mm]	126	150	174	228	284	344	384	430	470	512	552	
<b>Tensile <math>N_{Rd}</math>: single anchor, no edge effects</b>												
	HIT-V 5.8	12,0	19,3	28,0	52,7	82,0	118,0	153,3	187,3	221,1	251,9	284,0
	HIT-V 8.8, AM 8.8	19,3	30,7	44,7	84,0	125,2	164,5	196,3	230,0	221,1	251,9	284,0
	HIT-V-R	13,9	21,9	31,6	58,8	92,0	132,1	80,4	98,3	121,3	143,0	170,6
	HIT-V-HCR	19,3	30,7	44,7	84,0	125,2	117,6	152,9	187,1	144,6	170,4	203,3
<b>Shear <math>V_{Rd}</math>: single anchor, no edge effects, without lever arm</b>												
	HIT-V 5.8	7,2	12,0	16,8	31,2	48,8	70,4	92,0	112,0	139,2	163,2	195,2
	HIT-V 8.8, AM 8.8	12,0	18,4	27,2	50,4	78,4	112,8	147,2	179,2	222,4	261,6	312,0
	HIT-V-R	8,3	12,8	19,2	35,3	55,1	79,5	48,3	58,8	73,1	85,7	102,5
	HIT-V-HCR	12,0	18,4	27,2	50,4	78,4	70,9	92,0	112,0	87,0	102,0	122,0

Design resistance: concrete C 20/25 –  $f_{ck,cube} = 25 \text{ N/mm}^2$ , Temperature range I

Anchor size	ETA-16/0143, issue 2016-11-30								Additional Hilti technical data			
	M8	M10	M12	M16	M20	M24	M27	M30	M33	M36	M39	
Embedment depth $h_{ef,2} =$ [mm]	96	120	144	192	240	288	324	360	396	432	468	
Base material thickness $h_{min} =$ [mm]	126	150	174	228	284	344	384	430	470	512	552	
Edge distance $c = c_{min} =$ [mm]	40	45	45	50	55	60	75	80	165	180	195	
<b>Tensile <math>N_{Rd}</math>: single anchor, min. edge distance (<math>c = c_{min}</math>)</b>												
	HIT-V 5.8	12,0	19,3	24,6	36,7	50,4	65,4	79,1	92,1	98,9	112,7	127,0
	HIT-V 8.8, AM 8.8	14,2	19,3	24,6	36,7	50,4	65,4	79,1	92,1	98,9	112,7	127,0
	HIT-V-R	13,9	19,3	24,6	36,7	50,4	65,4	79,1	92,1	98,9	112,7	127,0
	HIT-V-HCR	14,2	19,3	24,6	36,7	50,4	65,4	79,1	92,1	98,9	112,7	127,0
<b>Shear <math>V_{Rd}</math>: single anchor, min. edge distance (<math>c = c_{min}</math>), without lever arm</b>												
	HIT-V 5.8											
	HIT-V 8.8, AM 8.8	3,9	5,0	5,5	7,4	9,5	12,0	16,5	19,1	45,0	52,3	60,0
	HIT-V-R											
	HIT-V-HCR											

Design resistance: concrete C 20/25 –  $f_{ck,cube} = 25 \text{ N/mm}^2$ , Temperature range I  
(load values are valid for single anchor)

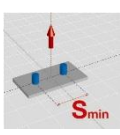
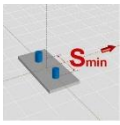
Anchor size	ETA-16/0143, issue 2016-11-30								Additional Hilti technical data		
	M8	M10	M12	M16	M20	M24	M27	M30	M33	M36	M39
Embedment depth $h_{ef,2} =$ [mm]	96	120	144	192	240	288	324	360	396	432	468
Base material thickness $h_{min} =$ [mm]	126	150	174	228	288	344	384	430	470	512	558
Spacing $s = s_{min} =$ [mm]	40	50	60	75	90	115	120	140	165	180	195
 <b>Tensile <math>N_{Rd}</math>: double anchor, no edge effects, min. spacing (<math>s = s_{min}</math>)</b> HIT-V 5.8 [kN] HIT-V 8.8, AM 8.8 [kN] HIT-V-R [kN] HIT-V-HCR [kN]	12,0	19,3	28,0	48,7	67,8	89,5	106,2	124,9	120,7	137,6	155,1
	17,3	24,2	31,8	48,7	67,8	89,5	106,2	124,9	120,7	137,6	155,1
	13,9	21,9	31,6	48,7	67,8	89,5	80,4	98,3	120,7	137,6	155,1
	17,3	24,2	31,8	48,7	67,8	89,5	106,2	124,9	120,7	137,6	155,1
 <b>Shear <math>V_{Rd}</math>: double anchor, no edge effects, min. spacing (<math>s = s_{min}</math>), without lever arm</b> HIT-V 5.8 [kN] HIT-V 8.8, AM 8.8 [kN] HIT-V-R [kN] HIT-V-HCR [kN]	7,2	12,0	16,8	31,2	48,8	70,4	92,0	112,0	139,2	163,2	195,2
	12,0	18,4	27,2	50,4	78,4	112,8	147,2	179,2	222,4	261,6	312,0
	8,3	12,8	19,2	35,3	55,1	79,5	48,3	58,8	73,1	85,7	102,5
	12,0	18,4	27,2	50,4	78,4	70,9	92,0	112,0	87,0	102,0	122,0